

FIREWOOD PROCESSORS

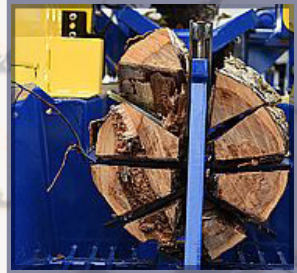

OPERATOR'S MANUAL

Models:

SC-12XP, SC-14, SC-15, SC-16





FACTORY SERVICE AND SUPPORT

888-820-3962 Toll Free
989-823-6200 Local Phone
231-660-7973 Service & Parts
231-734-3681 Fax
info@dyna-products.com
8440 State Rd
Millington, MI 48746 USA

Visit our website for a list of US Dealers.
www.dyna-products.com



Factory Located in Millington, MI
Made in the USA

TABLE OF CONTENTS

Introduction	4
Warranty Information.....	5
Safety Information.....	8
DYNA SC-12/SC-12XP Firewood Processor.....	25
DYNA SC-14 Firewood Processor.....	30
DYNA SC-15 Firewood Processor.....	37
DYNA SC-16 Firewood Processor.....	43
DYNA Diagram.....	50
Maintenance Tips.....	55
Parts Lists.....	57



INTRODUCTION

THANK YOU for purchasing your DYNA Firewood Processor. DYNA Products continues to be a market leader in the small to mid-size firewood processor category. Constant innovation, attention to detail, and customer feedback are the main driving forces behind our steady growth.

⚠️ IMPORTANT!! Please read and understand this entire Operator's Manual before setting up and operating your processor. Operators must familiarize themselves with the safety, mechanical and maintenance specifications along with operational instructions to ensure the successful, safe and long lived use of your processor.

If you have any questions, contact us anytime!

888-820-3962 Toll Free
989-823-6200 Local Phone
info@dyna-products.com

Visit our website at dyna-products.com

This manual is to provide the owner/operator with specifications and procedures for safety of operations, maintenance, and repair of your DYNA Firewood Processor. Safety should always be kept in mind when this machine is being operated, serviced, stored and transported.



WARRANTY INFORMATION

This equipment comes with a 3 year limited warranty. If any product or part is proved to be defective within 3 years from date of purchase, by reason, of improper workmanship and/or material we will replace, or repair at our discretion, the part or product at no charge to you.

To obtain warranty service, the customer must deliver the part or product to the factory address at their expense. A copy of the original sales invoice is required when requesting warranty work.

The warranty is limited to 60 days on the saw bar and 1 year on the splitter wedge and the conveyor belt. The saw chain is not covered. The KOHLER and HONDA engines are warranted according to their factory warranty (typically 2 years). The CAT/ KOHLER engines are also warranted according to their vendor. (typically 2 years)

The above warranty does not cover defects caused by modification, alteration, or repair of the part or product in question, by anyone other than the manufacturer. Physical abuse to, or misuse of the product or use or assembly thereof in any manner contrary to the accompanying instructions and will void warranty.

DYNA FIREWOOD PROCESSOR LIMITED WARRANTY (EXPLANATION OF APPLICATION)

During the warranty period the manufacturer of the DYNA Firewood Processor will provide the customer replacement or defective parts which qualify for warranty at no charge. It is the customer's responsibility to replace defective parts unless special arrangements are made with selling dealer or with the manufacturer. Labor costs for replacing chains, bearings, all hydraulic components, or any "bolt on" components such as splitter head, splitter back post, log decks, and engine are not reimbursed to customer. Defective parts are to be returned to DYNA Products at the customer's expense.

Any unapproved repairs or modifications attempted by any individual voids all warranty and liability obligations from the manufacturer. It is the customer's responsibility to deliver the

WARRANTY INFORMATION

machine to a Dealer or engine service center. Arrangements must first be made with either the manufacturer or the selling dealer. The manufacturer does not normally reimburse the customer for any traveling costs that occur in such cases.

All engine (CAT, KOHLER, or HONDA) warranties are handled through their manufacturer. (typically 2-3 years) These do not come under the warranty covered by DYNA Products. Contact info provided below.

CAT.....	231 734 4433
KOHLER General Power.....	800 508 3246
HONDA Pace Equipment	800 686 3128

Proper storage and adequate lubrication is important for this machine. Engine oil and coolant levels must be checked daily. Failure to replace wear parts or maintaining proper adjustments can cause consequential damage. Impairments caused by neglect on any of these issues are not covered by manufacturer's warranty.

Fire or heat damage caused by failure to remove canvas engine cover is not covered by manufacturer's warranty. This refers to damages of any kind to the cover, engine, or any part of the machine.

Transport damages such as road wrecks or any collision of any sort during transit are not covered by manufacturer's warranty.

Bolts and nuts should be checked periodically. All shielding and guarding must be properly installed and functional to keep warranties valid.

WARRANTY INFORMATION

Certain wear parts are not covered under this warranty. Saw bar, saw chain, canvas covers, and tires are not covered under any circumstances. Splitting wedge and discharge conveyor belt limited to a 1 year warranty.



Hydraulic components must be returned with all ports plugged or capped. Any contamination within the component will void the warranty. All components must be complete as shipped from factory.

Warranty is only valid when the machine has been operated under normal circumstances and was properly maintained according to manufacturer recommendations. Any damages caused by foreign material or logs that are larger than rated for this model are not covered by this warranty.

Owner agrees while requesting any warranty claims or reimbursements that only replacement parts or repairs of existing defective parts will be provided.

IMPORTANT SAFETY INFORMATION

This manual is to provide the machine owner/operator with specifications and procedures for safe operations, maintenance, and repair of this DYNA Firewood Processor. Safety should always be kept in mind as this machine is being operated, serviced, stored and transported. The noteworthy words are described below as each issue is addressed in the following pages.

Noteworthy Word	Likelihood of Occurrence	Degree of Injury or Damage
 DANGER	Will occur if warning is ignored	Severe
 WARNING	Can occur if warning is ignored	Severe
 CAUTION	Will or can occur if ignored	Minor or Severe
NOTICE	Important, but not hazard related	Minor

This equipment was designed and manufactured with safety in mind. This by itself will not prevent injury. It is the operator's responsibility in practicing good judgment during operation of this machine. It is important that all safety procedures are followed as described in this manual. The operator has the full responsibility to follow all OSHA and ANSI guidelines.

DANGER

Any person that is intoxicated or mentally impaired by alcohol or any form of drugs must stay at least 100' away from the machine. Any unreasonable and senseless behavior is prohibited anywhere near the general vicinity of the machine. Any person operating the machine in such condition could result in severe injury or death.

IMPORTANT SAFETY INFORMATION

WARNING

Improper use of this machine can result in severe injury or death. Only qualified personal are allowed to operate this machine. All potential operators must be trained and familiarized with this manual before operating the DYNA Firewood Processor

WARNING

It is the responsibility of the owner of this DYNA Firewood Processor to train and qualify the operators of this machine. The owner also assumes the authority and responsibility to insure that all operators are practicing the “Safety of Operation” described in this manual while operating, transporting and servicing this machine. Performing scheduled preventive maintenance and following manufacturer’s repair recommendations is the owner’s responsibility and the lack thereof can cause machine harm and personal endangerment. Any unapproved modifications or repairs without manufacturers approval will void all warranties and can cause damage to the machine and result in severe personal injury or death.

NOTICE

The manufacturer of the DYNA Firewood Processor reserves the right to make modifications or changes to this machine without advanced notice. It is the owner’s responsibility to stay current with all advancements in safety procedures that are required by the manufacturer of the DYNA Firewood Processor. See more information in the Warranty Section, page 5-7.

IMPORTANT SAFETY INFORMATION

SAFETY OF OPERATION

DANGER

This machine was built and designed with your safety in mind. Your physical well-being is important to us. Decals and guarding were installed on your machine for your safety. It will only serve as your protection if the decals are read, understood, and followed as indicated. Guarding should be left installed and maintained.

All operators or potential operators are to read and understand the complete owner's manual. It is the owner of this machine's responsibility to insure that all individuals operating this machine are properly trained and qualified according manufacturer's recommendations. Any individual who has not read and understood this owner's manual and decals is **NOT** qualified to operate this machine. The operator's safety is dependent on the individual's knowledge of this machine and how to safely operate this machine at full potential.

WARNING

Almost all accidents occur when proper operator safety procedures are not followed or machine has not been properly maintained and/or adjusted to manufacturer recommendations. Operator mistakes normally occur when the individual has operated the machine for a length of time. After the operator is accustomed to the machine the alertness and cautiousness has a tendency to fade away. Reaching into splitter area while splitter is in motion, steadying the log while feeding log forward or holding onto the wood while saw is in function are some common mistakes made when accidents happen. Usually these mistakes are made by experienced operators. Always maintain the initial operator alertness throughout all the time spent operating this machine.

IMPORTANT SAFETY INFORMATION

This machine is intended to be operated by experienced machinery operators. Operator shall also be aware of any additional personnel in the general vicinity. Each person should always know the whereabouts of the other person(s). Operators are to be familiarized with the safety of operation of this manual.

CAUTION

Keep children, bystanders and animals at least 100' away from machine while in operation. Beware of any potential flying pieces of wood from saw or out of the splitting wedge. Logs on the deck also have the potential to fall or possibly roll off causing severe damage to the machine or to the operator and any bystanders.

CALIFORNIA

Proposition 65 Warning

Diesel engine exhaust fumes and some of its constituents are known to the State of California to cause cancer, birth defects, and other reproductive harm.

DANGER

Before starting machine make a circle around your machine. The machine area should be restricted to any by-passers. It is absolutely necessary that the operator has unobstructed access to the machine with no protruding branches, logs, stumps, or uneven ground to cause tripping and possibly result in severe injury. The log deck and discharge conveyor should be secured. Check for loose components, tools, or foreign objects in or on any part of the machine. Check for blown or leaky hoses or disconnected fuel lines. Make sure all caps are on reservoirs or tanks and are tightly secured. Make sure all canvas covers are removed while in operation.

IMPORTANT SAFETY INFORMATION

WARNING

Operator must always be on alert for any potential dangers. Also be watchful for any emergency shut-downs caused by equipment failures or unpredictable sudden harmful situations caused by jammed or falling wood or logs that could result in personal harm or injury. Operator must always be accessible to the controls and shut-down features of the machine.

DANGER

Always make sure loose clothing and gloves are contained to prevent any danger of snagging on logs, wood and any moving parts. Long hair, neckties, jewelry, shirt tails, loose shirt sleeves or open coats all have potential danger of catching in moving machinery parts or wood. Always make sure shoe strings are properly tied and not in excessive length to prevent tripping and falling in or against machine resulting in severe injury. Never wear shorts, short sleeve shirt or open toed shoes while operating the machine.

Always follow your local OSHA standards in wearing protective equipment. Never operate the machine without the following equipment: safety glasses and face shield, hard hat, hearing protection, strong gloves, long sleeve shirt or coat.

IMPORTANT SAFETY INFORMATION

NOTICE

Decals have been installed on your machine for your own safety and information. It is important that these remain installed at all times. Read and follow all the safety guidelines described on these decals. In the event that any of these decals are damaged, removed, or torn off, replacements should be ordered from the manufacturer.



DANGER

No person should ever climb onto or into the machine while it is running. Moving parts will cause severe injury if allowed to catch on a person's clothing or a body part. Never ride on the machine while in transit.

DANGER

Never stand underneath discharge conveyor at any time. Falling wood can potentially injure someone. Do not stand near the woodpile that has accumulated underneath conveyor, since wood has a tendency to avalanche down from the top and potentially hit bystanders. Never stand within 30' of the saw. Wood chips can fly a long way at a high rate of speed. Saw chain can potentially break and fly off the bar. A chain hitting someone will result in severe injury or death. Sometimes as wood is being split, small pieces can fly out of splitting area (especially frozen wood). It is absolutely essential that no person other than the operator is closer than 30' of the splitting area while machine is in operation. Being hit by a piece of flying wood can cause injury and is very dangerous. Never pass underneath log deck while logs are loaded. Falling logs will cause severe injury or death.

IMPORTANT SAFETY INFORMATION

WARNING

After new machine has been in operation for approximately 2 hours, stop machine and go over all the bolts and nuts. Tighten any loose bolts or nuts. Running machine with loose components can potentially cause serious machine failure or harmful situations. Vibration can loosen any fasteners during transport.

WARNING

After new machine has been in operation for approximately 2 hours, stop machine and go over all hydraulic fittings. Watch for any leakage or oily spots around hose connections. Tighten any fitting that seems to be loose. Beware of potentially hot oil causing serious burns. Always check oil temperature at any time before attempting to work on the hydraulic system. Allow oil to cool down to ambient temperature before doing anything with the system. Never work with hydraulic oil or its components without hand protection and eye protection.

DANGER

ALWAYS remember to remove the canvas cover from engine before starting the engine. Heat from the muffler will ruin the cover and potentially engulf the engine in flames.

DANGER

Always secure safety chain on the discharge conveyor. Do not use winch cable to support your conveyor. Never stand underneath conveyor even if it isn't running. Failure of the cable winch or safety cable will allow the conveyor to collapse resulting in severe injury. Be sure the log deck leg pins are properly in place before loading logs onto the deck. Log deck will collapse if pins are not in place. Always install safety brackets onto the conveyor before transit.

IMPORTANT SAFETY INFORMATION

DANGER

NEVER reach into saw area while engine is running. Saw chain is extremely dangerous if in motion. One can lose body parts by saw before one knows what happened.

NEVER reach into splitting area while engine is running. Extreme pressure is applied as splitting ram pushes wood through wedge. Wood will at times snap upward from where ram is pushing against. Hands can potentially be pinched in or be hit by flying wood. As wood passes through splitting wedge, at times the piece will fling off small pieces as it breaks open, or piece will at times completely fly out of the splitter itself. Severe injury or loss of a body part will result if hands are caught or pinched in this action.

NEVER reach in around motor chains, deck chains, cables, sprockets, or any moving component of this machine. Never remove any guarding of any kind.

DANGER

Never attempt to process logs with nails, wire, stones, any kind of hardware or foreign object. These objects can cause breakage of equipment and become a potential missile.

Never attempt to process logs with vines or vine-like materials wrapped around the log. This can result in dragging in body parts or catching onto machine components causing machine damage or personal injury. If vines or branches get wrapped around sprockets or shafts, immediately stop the engine and remove the material.

IMPORTANT SAFETY INFORMATION

DANGER

NEVER operate this machine indoors or in any enclosed or unventilated area. Engine exhaust fumes can cause severe sickness or death. Never refuel in an unventilated area or while engine is running. **DO NOT SMOKE WHILE REFUELING OR OPERATING THE MACHINE.** Be careful to not overfill the fuel tank. Clean up any spilled fuel before starting machine. Follow recommended oil changes for the engine.

WARNING

Never jump start your engine during freezing temperatures. A frozen battery can be explosive. Always first warm the battery before attempting to use jumper cables. Watch for a bulging battery or ice formation within battery acid. Insure your battery has the proper cold cranking amps while starting in cold conditions. Always keep battery in a ventilated area since battery fumes are explosive. Never allow battery acid to make contact with your skin or clothes since it is extremely corrosive and will severely burn. Never allow battery to be exposed to sparks or open flame. Always use face and hand protection when servicing a battery. Always keep battery in the enclosure on the machine.

DANGER

Always keep machine well maintained and any broken or worn parts replaced. Never remove any guarding or safety devices from the machine. Replace any shields after one happens to be destroyed or lost.

Before servicing any part of machine, shut engine off and remove key from ignition.

DANGER

IMPORTANT SAFETY INFORMATION

Beware of hot engine muffler or any other component of the machine. Severe burns can result by making contact with a heated part.

CAUTION

Do not slam log deck arms down from raised position. Hinge or pivot bolt could break, consequentially causing severe injury. Keep hands and arms away from the hinge or chains while lowering the deck arms. These are severe pinch points. Beware of deck arm leg sliding out of arm. This will happen if leg is not properly pinned onto the arm. Double check all pins before attempting to raise or lower deck arms. Always make sure deck arm legs are firmly resting on the ground before operating the machine.

NOTICE

Always lower front stabilizer leg before operating or after parking the machine. Never rely on the jack for machine stability in operation or storage. Always park the machine on level ground. Always keep tire pressure at recommended levels.

DANGER

Never attempt to operate the machine on any kind of slope. The machine can slowly move or creep away from the proper location causing potential personal injury or equipment damage.

DANGER

Never operate the the machine without the conveyor safety chain properly hooked. Failure to do so could potentially cause the conveyor to collapse causing injury or death.

IMPORTANT SAFETY INFORMATION

WARNING

Before transporting machine follow the transportation procedures of this manual found in the “Transportation Procedures” section. Always use the correct size ball or hitch coupler. Always fasten safety chains onto hitch by crossing them underneath the tongue. Make sure jack and stabilizer leg is fully retracted and secured. Double check the hitch lock and insure it is properly latched before taking off. Make a round surrounding the machine, double checking that the deck arms are securely pinned, discharge conveyor safety chain is properly hooked, conveyor transport brackets are installed, and there are no loose pieces of wood or tools on the machine. Watch for any dangling machine parts that might be loose or broken. Make sure all caps on tanks are tight and properly secured. Remove keys from ignition to avoid losing them. If equipped with lights, make sure they are working properly. Check tire pressure and make sure wheel lugs are tight.

DANGER

Operator or any bystander must be a minimum of 30’ from machine while logs are loading onto deck. Falling or rolling logs will cause severe injury or possibly death. Personnel loading logs onto deck must very careful and watchful of hitting or hanging forks or bucket on machine or deck. Lowering logs onto deck must be done very slowly and carefully. Always beware that logs will potentially start rolling or falling against machine causing machine damage or injury.

DANGER

Never climb into the conveyor at any time. Never ride on the conveyor belt while in motion or in transport. Never remove a piece of wood from the conveyor while in operation. Never reach underneath the conveyor while in operation. Never remove any foreign objects such as sticks, bark, branches, slivers or any

IMPORTANT SAFETY INFORMATION

kind of material lodged anywhere on the conveyor while the machine is in operation. This refers to the flat rollers, frame, belt, or the bearings. Any contact with a moving belt is always very dangerous and will grab any clothes or body parts, potentially dragging a person into the machine and consequentially causing injury or death.

SAFETY IN SET-UP PROCEDURES

WARNING

Any person that is intoxicated or mentally impaired by alcohol or drugs must stay at least 100 ft. away from the machine. Any unreasonable and senseless behavior is prohibited anywhere near the general vicinity of the machine. Any person operating the machine in such condition will result in severe injury or death.

WARNING

Improper use of this machine can result in severe injury or death. Only qualified personnel are allowed to operate this machine. All potential operators must be trained and familiarized with this manual before operating this Dyna Firewood Processor.

CAUTION

Be cautious of the site selection which you plan on operating this machine. Absolutely no slope is necessary for both smooth operation and safety of the operator. As logs advance toward saw feed deck and as wood falls into splitter it is essential that the machine is on a level plane.

IMPORTANT SAFETY INFORMATION

WARNING

As you plan your location consider the saw discharge area. The saw will project dust, chips and debris at least 10 feet from machine. This material can cause injury or damage to the eyes. Insure your discharge conveyor will deposit the wood into a safe area, which could potentially fall or avalanche into someone or something which would cause damage or personal injury.

The following steps must be taken for each initial set-up:

- 1) Check all the safety decals, gauge, fluid levels and the condition of saw. Replace or replenish as needed.
- 2) Check for any broken or worn parts, chains or hydraulic components. Repair or replace as needed.
- 3) Make sure daily maintenance is up-to-date on engine. Refer to engine manual for daily maintenance instructions.
- 4) Check for any loose nuts and bolts. Watch for any dangling components or hose. Tighten as needed.
- 5) Check all the guarding. Make sure each one is totally functional and intact. Replace or repair any damages.
- 6) Place your machine in a level spot. Point your discharge conveyor into safe location. Insure that your saw discharge is also pointing in a safe direction.
- 7) Lower your front stabilizer leg before lowering the jack. Securely pin the stabilizer leg at the correct height. After stabilizer leg is secured, lower jack until it raises the machine and unhook the hitch from vehicle. After vehicle is removed from the area, lower the machine with the jack until stabilizer leg is bearing approximate equal amount of weight.
- 8) Double check that the machine is level and stabilized in all four corners.
- 9) Remove canvas covers from controls and engine. **WARNING** Failure to remove cover from engine before starting engine will ruin cover and potentially harm the engine and machine .

IMPORTANT SAFETY INFORMATION

- 10) Make sure everything is clear of the discharge conveyor. Totally remove the two stabilizer brackets from the conveyor. Unhook the safety chain up by the winch and make sure chain is not able to snag anywhere on the machine.
- 11) Carefully lower the conveyor by the cable winch until wheels on upper section rest on the ground and the winch cable has some slack.
- 12) Securely latch the upper section to the lower section. **BEWARE!** Make sure latch handle is fully retracted.
- 13) Raise the conveyor to proper operating height. Do not exceed the angles shown below.
- 14) Hook conveyor safety chain to the hook beside the winch. Lower cable winch until the weight is on the safety chain. **BEWARE!** Never operate the machine without the safety chain properly hooked.
- 15) Remove log deck pin.
- 16) Lower log deck.
- 17) Unpin deck arm legs. Locate right hole in leg so that arm is approximately level horizontally. Re-pin the log deck arm and the leg. **BEWARE!** Insure the small keeper pin is properly secured and lock to the main pin.
- 18) Remove the engine and control panel covers. **BEWARE!** Never install cover on a hot engine. This will ruin the cover and potentially cause fire.
- 19) Before operating the machine, check the saw chain for sharpness. Remove chain and sharpen or replace with another sharp chain if needed. Never operate a machine with a dull chain.
- 20) Go over your daily maintenance check list before operating the machine.
- 21) Follow all safety precautions described in this manual.

SAFETY IN TRANSPORT PROCEDURES

IMPORTANT SAFETY INFORMATION

CAUTION

Absolutely never attempt to work on a hot machine.
Always allow all components of the machine to reach ambient temperatures before any transport preparations or any maintenance procedures.

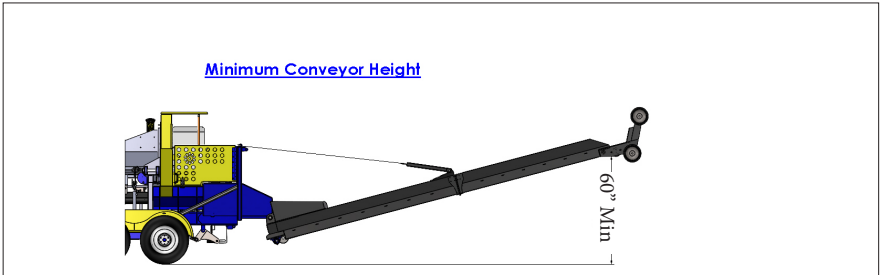

**Always use
safety chain on
conveyor!**

IMPORTANT SAFETY INFORMATION

WARNING











Always make sure the engine muffler and hydraulic pump is cooled down to ambient temperature before installing engine cover. Canvas covers are not under manufacturer's warranty under any circumstances.

- 1) After machine has been cooled to ambient temperatures, remove all loose pieces of wood, bark, branches, and any foreign debris on any part of the machine. Clear all excess wood out of the splitter. Make sure all debris is cleared underneath the machine.
- 2) Unhook safety chain from discharge conveyor. Lower the conveyor down all the way to the ground.
- 3) Unlatch the upper and lower sections of the conveyor.
- 4) Winch the conveyor all the way up to transport position. As conveyor is being raised, carefully watch for any obstructions that might hinder the wheels from rolling freely or any obstacles preventing the conveyor from folding together.
- 5) Install the two/four conveyor transport brackets. Make sure the brackets are all secured properly with the locking pins.
- 6) Unpin and raise the log deck legs. Repin at the leg on the highest point possible. Do the same for all of the legs.
- 7) Lift the deck and allow it to swing in against the transport stops. Follow all safety precautions as described previously. Watch out for all pinch points as described on the decals.
- 8) Secure the deck with the safety pin against the transport stops. (Model SC12 – support brackets)
- 9) Install the engine and control panel covers.

SAFETY OVERVIEW

The DYNA firewood processor is a machine that can cause great bodily injury or death to persons operating it incorrectly or those within close vicinity.

It is the operator's responsibility to keep him/herself safe and those around him/her.

-  Never use the firewood processor for anything but wood processing.
-  Be sure to always wear hard hat, safety goggles, and safety clothing such as gloves, coats, chaps, boots and ear protection.
-  Never reach into the saw area while the machine is running. The chainsaw can cause serious injury.
-  Never reach into the splitting area with the machine running. The log splitter ram and wedge can cause serious injury.
-  Never stand or walk underneath the conveyor. The conveyor could collapse or falling blocks of wood may hit a person. The conveyor can cause serious injury.
-  Never reach into any moving parts of the machine, such as, chains, sprockets, saw bar, splitter ram, wedge, motors, cables and even wood chunks.
-  ALWAYS use a safety chain to support the conveyor securely, while conveyor is extended and while traveling in the transport position.
-  ALWAYS, use safety chains on the hitch and use proper lighting when traveling on a road.
-  ALWAYS keep out from under the logs on the deck. They could drop and cause serious injury.
-  CAUTION! Maintain full attention on splitting wedge and keep hand on splitter lever while splitting ram is in forward motion.
-  Never operate the firewood processor while under the influence of alcohol or drugs

SC-12XP • SET UP

SETTING UP YOUR FIREWOOD PROCESSOR

⚠️ Read and understand this entire section for proper and safe set up.

To set up the firewood processor conveyor, follow these steps:

1. Start by removing transport safety bars.



2. Turn the manual winch counter clockwise to lower the conveyor to a convenient height for your processing needs.



- ⚠️** NEVER stand underneath the conveyor.
- ⚠️** ALWAYS USE SAFETY CHAIN ON CONVEYOR!

SC-12XP • SET UP

The HONDA gas engine can be safely operated at 3600 rpm. The speed is typically set at the factory. The engine should be choked for approx 5 seconds.

The oiler knob must be turned on at all times to supply oil to the saw bar. See Fig 1 The knob must be turned only approximately 1/2 turn. You should see oil dripping off the chain sprocket. The bar should be getting enough oil to prevent discoloring from overheating. If you get excessive oil, you may experience a spray or mist hitting the operator. This indicates too much oil. The system will apply oil continuously. You must turn off the oiler when shutting down the engine.

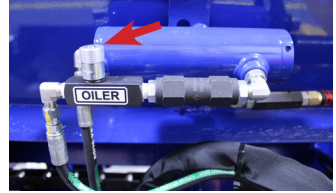

FIG 1

Use winter grade bar and chain oil. The hydraulic system uses a standard 46 weight hydraulic fluid.



FIG 2

Keep the oil level checked daily. It should always be in between the high and low marks on the level gauge. The temperature gauge is also on the level. It should not exceed 180 degrees Fahrenheit. Running in excess could damage the hydraulic system. The tank holds 15 gallons of hydraulic fluid

and can be filled by opening the cap on the top, see Fig 2. Check the level before you run the machine.



The log deck needs to be lowered before the logs can be placed on top. Be careful to keep hands away from the hinge points.

FIG 3 These are serious pinch points and can cause serious injury, see Fig 3. The legs must be dropped to the ground for loading one log at a time or set horizontally for multiple log loading, and pinned into place. The logs can then be loaded onto the log deck. It works best to keep the row of logs single without piling them on top of each other.

SC-12XP • SET UP

OPERATION OF THE MACHINE

The logs can now be advanced toward the in-feed trough and deposited one at a time. The hydraulic controls have appropriate instructions for the travel direction of the chains. Be sure to use only one function per lever simultaneously.

The log is then brought into position to the marker. This marker is adjustable up to 24” lengths. See Fig. 4. Next, pull the lever for the clamp. See Fig. 4. When it is clamped then pull the saw lever. See Fig. 4. The log saw motor will automatically start at this point and will stop when the saw is returned to home. The log will drop into the splitter hopper and the lever must be pushed the opposite direction to raise the saw. Release the clamp when the saw is in the upper (home) position and advance the log hydraulically for the next cut. The log is split using the right hydraulic lever. NEVER split with excess log mass on a horizontal wedge wing only or by splitting a piece of wood in a vertical position. This causes excess fatigue on the wing and can bend or break it. The warranty on the wedge is voided if this happens. While the splitter is returning, you may advance the log into position again. You must never attempt to saw a log while the splitter ram is in motion. These two functions must be operated independently. ALWAYS watch the splitting operation while splitting a log.



Fig.4

SC-12XP• OPERATION - CONT'D

After the wood exits the splitter, it will push itself out onto the pile or a conveyor (if supplied). The conveyor may be turned on by the control knob See Fig. 5. The speed may also be varied by this valve. Always be sure to stay out from under the conveyor.



Fig. 5

HYDRAULIC ADJUSTMENTS

The hydraulic pressure can be monitored by the gauge beside the control panel. The relief valve pressure adjusts higher by turning clockwise. The relief valve has a cap that needs to be turned off and a jam nut that needs to be loosened before adjusting. See Fig 6.



Fig. 6

The Splitter Pressure should read max 2800 psi with a 20 HP engine. You can get that reading by stalling the splitter cylinder in the retract (home) position. To adjust, turn the relief valve on the splitter valve. See Fig 8.

To change conveyor speed, adjust the relief valve on the return manifold under the control panel. See Fig. 7.



Fig. 7



Fig. 8

SC-12XP• MAINTENANCE

MAINTENANCE

The bearings should be greased with one shot of grease every 200 hours. The engine must be maintained according to the instructions of the engine manual. The saw chain (.404) must be sharpened or replaced whenever it is dull. If it dulls on one side it may pull the bar to the side and cause binding. This machines 18" bar requires an 68 tooth drive link for its chain. The hydraulic fluid is standard 46 weight and should be checked daily. Use winter grade bar and chain oil for the saw bar. Change the hydraulic filter every 250 hours of use. Use Zinga filter # HE-10L. See Fig 16. Check the air filter every 20 hours. Clean them if dirty. Change the engine oil every 50 running hours. Grease the main splitter slider daily. Refer to and follow instructions in the HONDA engine manual.

CONTINUED ADJUSTMENTS

Check the log loader chain weekly. Tighten it to snug if it is loose. You may use the log loader as a log deck with or without the log dogs. If you wish to use the SC-12 without the dogs you may replace the chains with a master link. Call the factory for these if they are not supplied.

If the detent on the splitter return does not stay engaged while retracting. See Fig 8.

- 1.) Loosen jam nut.
- 2.) Turn clockwise approximately 1/4 turn to increase detent. Then re-tighten jam nut.

SC-14 • SET UP

SETTING UP YOUR FIREWOOD PROCESSOR

⚠ Read and understand this entire section for proper and safe set up.

To set up the firewood processor conveyor, follow these steps:

1. Lower it with the electric winch until the conveyor is on the ground.

2. Snap the locks on both sides of conveyor securely into place. See Fig 1.



Fig. 1

3. Raise the conveyor to a convenient height. See Fig 2
Then fasten the safety chain.

4. Lower stabilizer leg to the lowest hole, then lower the jack until you have weight on both legs.



Fig. 2

⚠ NEVER stand underneath the conveyor.

⚠ ALWAYS USE SAFETY CHAIN ON CONVEYOR!

SC-14 • SET UP CONT'D

THE KOHLER GAS ENGINE:

Can be safely operated at 3700 rpm. This is typically set at the factory. If you are running a diesel please refer to the CAT manual provided.

The oiler must be turned on at all times. You should see oil dripping off the chain sprocket. The bar should be getting enough oil to prevent discoloring from overheating. If you get excessive oil, you may experience a spray or mist hitting the operator. This indicates too much oil. The system will apply oil every time the saw bar is coming down. You will need to watch the oil level. You may need to add several quarts per day. The second option is a dedicated oiler. The oil reservoir is on the back shield with the oil pump below. The control is on the oiler pump.

THE HYDRAULIC SYSTEM uses a **standard 46 weight hydraulic fluid**. Check the oil level daily. It should always be in between the high and low marks on the level gauge. The temperature gauge is also on the level. It should not exceed 180 degrees Fahrenheit. Running in excess could damage the hydraulic system. The **tank holds 25 gallons of oil** and can be filled by opening the toolbox.



Fig. 3

See Fig 3 Check the level before you run the machine.

The log deck needs to be lowered before the logs can be placed on top. These are serious pinch points and can cause serious injury, see Fig 4. The legs must be dropped to the ground or set on blocks and pinned into place.

The logs can now be loaded onto the log deck. It works best to keep the row of logs single without piling them on top of each other. ALWAYS keep out from under the logs on the deck. They could drop and cause serious injury. Never load logs from the engine side of the machine.



Fig. 4

SC-14 • OPERATION

OPERATING THE MACHINE

The logs can now be advanced toward the in-feed trough and deposited one at a time.

The joystick controls have appropriate instructions for the travel direction of the chains. See Fig 5. Be sure to use only one function per joystick at a time.

The log is brought into position to the orange marker. See Fig 6.

Next, pull the lever for the clamp, when it is clamped, the saw will automatically start and travel through the log. The log will drop into the splitter hopper and the lever must be pushed the opposite direction to raise the saw. The clamp will open when the saw reaches the up position. The log is split using the middle splitter lever.

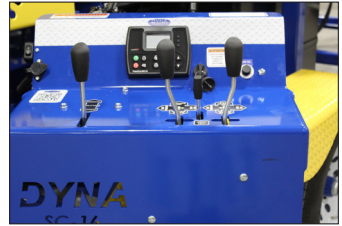

Fig. 5

The 4-way wedge may be raised to the log's center to maximize the split. Be sure and keep the log centered across the wedge especially with the 4-way wedge. NEVER split with excess log mass on a horizontal wedge wing only. This causes excess fatigue on the wing and can bend or break it. The warranty on the wedge is voided if this happens.



Fig. 6

While the splitter is returning, you may advance the log into position again. You must never attempt to saw a log while the splitter ram is in motion. These two functions should be operated independently for best results. The splitter valve will automatically snap into neutral when the cylinder bottoms out.

After the wood exits the splitter, it will push out onto the conveyor (if supplied).

The conveyor may be turned on by the control knob (see Fig. 7)

The speed may also be varied by this valve. The conveyor can be

SC-14 • OPERATION CONT'D

adjusted for height with the hand winch. Always be sure to stay out from under the conveyor at all times.

Conveyor Control

HYDRAULIC ADJUSTMENTS

The relief valve pressures always adjust higher by turning clockwise or tight. The relief valve has a cap that needs to be turned off and a jam nut that needs to be loosened before adjusting.



Fig. 7

The **conveyor pressure should read**

1250 psi. To test this pressure, raise the clamp and hold it while reading. This is not a critical pressure, but in case you need to adjust it, you must adjust the relief valve behind the oil tank, see Fig 11

The Splitter Pressure should read 2800 psi to 3000 psi. You can get that reading by stalling the splitter cylinder in the extended position. To adjust the detent on the splitter valve retract: remove the yellow cap and turn the adjustment bolt in to hold tighter. See Fig 8

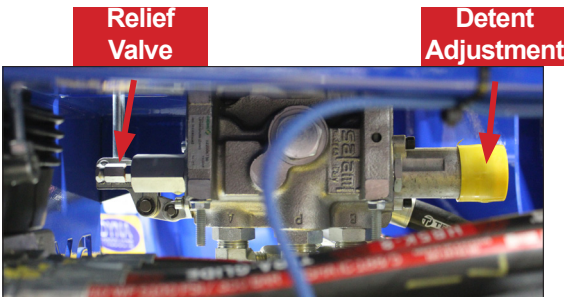

Fig. 8

SC-14 • OPERATION CONT'D & MAINTENANCE

The Clamp Pressure should be approx 600 psi. This can be read by completely lowering the clamp. If the pressure is too low, the saw motor will start softly or hesitate. The relief valve for this is located at the top of the control block. See Fig 9.

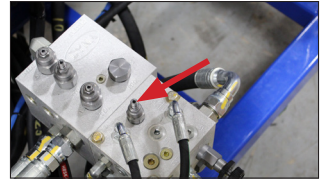

Fig. 9

The Saw Feed Pressure should be set at approximately 95-110 psi. If it is adjusted too high, the saw motor will stick and stall. If it is too low it may feed slowly or it may pulse. Try to adjust it as high as possible without stalling the saw. The relief valve is located on the side of the control block, the hand knob. See Fig 10.

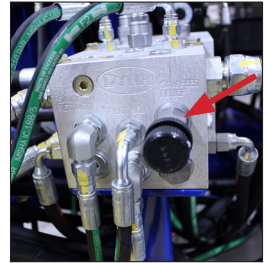

Fig. 10

MAINTENANCE

The bearings should be greased with one shot of grease every 200 hours of use.

The engine must be maintained according to the instructions of the engine manual. The saw chain (.404) must be sharpened or replaced whenever it is dull. If it dulls on one side it may pull the bar to the side and cause binding. This machine's 20" bar requires a 78 tooth drive link for its chain. The hydraulic

fluid is standard 46 weight hydraulic fluid and should be added daily to compensate for the oiler usage. Keep the soft start pivot greased daily, see Fig 11. Change the hydraulic filter every 250 hours of use. See Fig 12. Check the air filter every 20 hours. Clean them if dirty. Change the engine oil every 50 running hours.

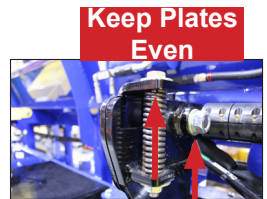

Fig. 11

Do Not Tighten

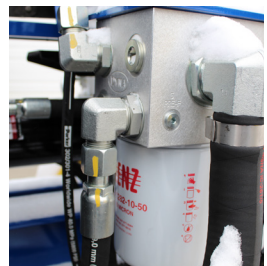

Fig. 12

SC-14 • MAINTENANCE CONT'D

Adjust clockwise to decrease oil flow and counterclockwise to increase oil flow. Your chain should be moist with oil. If oil is misting away from chain while it is engaged, your flow should be slightly decreased. If your chain is not freely moving on the bar and seems restricted or hot, slightly increase your oil flow.

The flow control for the dedicated oiler is located on the oiler pump. See Fig. 13 Adjust this knob counterclockwise this will increase flow and clockwise will decrease flow.

Fig 13

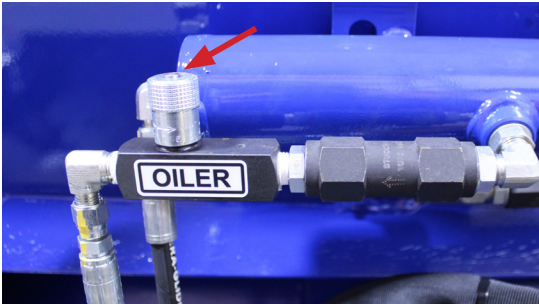

SC-14 • TROUBLE SHOOTING

PROBLEM	SOLUTION
SAW MOTOR STALLS	The pressure on the saw feed cylinder may be too high. It should be approximately 75 psi. See Fig. 10. The soft start spring may be set too hard or the saw chain may be dull. Check splitter pressure to make sure it is in correct parameters.
THE SPLITTER STALLS	The pressure may be too low. This should be between 2500-3000 PSI. See Fig. 8.
SAW MOTOR STARTS HESITANTLY OR SLOWLY	The relief valve on the clamp may be set too low. It should be set at 600 psi. See Fig. 9. The aluminum cap on top of the selector valve may need to be cleaned.
SAW LACKS POWER	The relief valve may be set too low on the splitter valve. See Fig.8 The aluminum cap on top of the selector valve may need to be cleaned. .
THE SAW BAR DOES NOT CUT ALL THE WAY THROUGH THE LOG	Increase saw feed pressure to 110 psi Replace bar and chain. A worn bar will cause a good chain to bind.
SPLITTER DETENT NOT HOLDING TILL FULLY RETRACTED	With hydraulic oil warmed to operating temperature. Adjust detent adjustment bolt in until it holds.
THE SAW BAR HITS GUARD WHEN IT RETURNS	The saw bar pivot needs adjustment forward. Check that the softstart plates are even on the top when the sawbar is in the up position. See Fig.11 Adjust the saw feed clevis up.
ENGINE STARTS HARD	Use fresh clean fuel. Do not use ethanol type fuels. Check and replace air and fuel filters. Check spark plugs(on gas models). Check glow plugs(on diesel models).

SC-15 • SET UP

SETTING UP YOUR FIREWOOD PROCESSOR

⚠ Read and understand this entire section for proper and safe set up.

To set up the firewood processor conveyor, follow these steps:

1. Lower conveyor with the electric winch until the wheels touch the ground.
2. Snap the locks securely into place, see Fig 1.
3. Raise the conveyor to a convenient height, see Fig 2 then fasten the safety chain.
4. Lower stabilizer jack leg to the lowest hole, then lower the jack until you have weight on the jack.

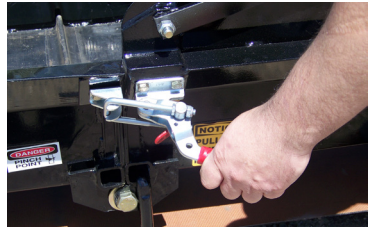

Fig. 1



Fig. 2

⚠ NEVER stand underneath the conveyor.

⚠ ALWAYS USE SAFETY CHAIN ON CONVEYOR!

SC-15 • SET UP CONT'D

THE KOHLER GAS ENGINE:

The motor can be safely operated at 3700 rpm. This is typically set at the factory. If you are running a diesel please refer to the CAT manual provided.

THE HYDRAULIC SYSTEM uses a **standard 46 weight hydraulic fluid**. Check the oil level daily. It should always be in between the high and low marks on the level gauge. The temperature gauge is also on the level. It should not exceed 180 degrees Fahrenheit. Running in excess could damage the hydraulic system. **The tank holds 25 gallons of oil** and can be filled by opening the top of the toolbox. See Fig 3. Check the level before you run the machine.

The log deck needs to be lowered before the logs can be placed on top. These are serious pinch points and can cause serious injury, see Fig 4. The legs must be dropped to the ground or set on blocks and pinned into place.

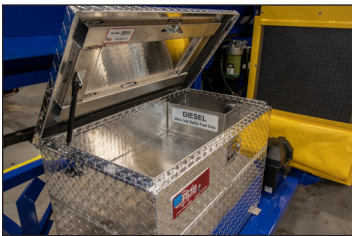

Fig. 3



Fig. 4

The logs can now be loaded onto the log deck. Never load logs from the engine side of the machine. It works best to keep the row of logs single without piling them on top of each other. ALWAYS keep out from under the logs on the deck. They could drop and cause serious injury.

SC-15 • OPERATION

OPERATING THE MACHINE

The logs can now be advanced toward the in-feed trough and deposited one at a time.

The joystick controls have appropriate instructions for the travel direction of the chains. See Fig 5 Be sure to use only one function per joystick simultaneously.

The log is then brought into position to the orange marker.

See Fig 6.

Next, pull the lever for the clamp, when it is clamped, the saw will automatically start and travel through the log. The log will drop into the splitter hopper and the lever must be pushed the opposite direction to raise the saw. The clamp will open when the saw reaches the up position. To split the log after the cut you will use the middle lever.

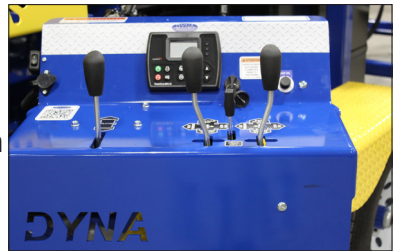

Fig. 5

The 4-way wedge may be raised to the log's center to maximize the split. Be sure and keep the log centered across the wedge especially with the 4-way wedge. NEVER split with excess log mass on a horizontal wedge wing only. This causes excess fatigue on the wing and can bend or break it. The warranty on the wedge is voided if this happens.



Fig. 6

While the splitter is returning, you may advance the log into position again. You must never attempt to saw a log while the splitter ram is in motion. These two functions should be operated independently for best results. The splitter valve will automatically snap into neutral when the cylinder bottoms out.

SC-15 • OPERATION CONT'D

Your machine is equipped with a dedicated oiler system. Flow control for the dedicated oiler is located on the oiler pump. See Fig. 7 Adjust this knob counterclockwise this will increase flow and clockwise will decrease flow.

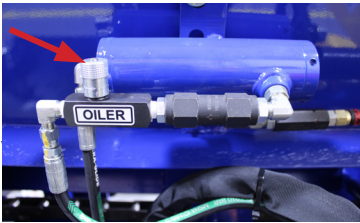

Fig. 7

MAINTENANCE

The Clamp Pressure should be approximately 600 psi. This can be read by completely lowering the clamp. If the pressure is too low, the saw motor will start softly or hesitate. The relief valve for this is located at the top of the control block. See Fig 8.

The Saw Feed Pressure should be set at approximately 95-110 psi. If it is adjusted too high, the saw motor will stick and stall. If it is too low it may feed too slowly or it may pulse. Try to adjust it as high as possible without stalling the saw. The relief valve is located on the side of the control block where there is a hand knob See Fig. 9.

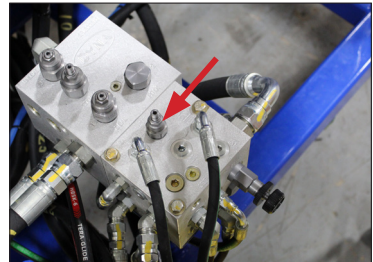

Fig.8

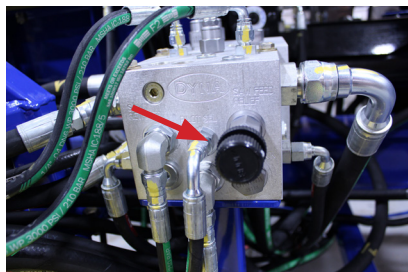

Fig. 9

SC-15 • MAINTENANCE

The Splitter Pressure should read 2800 psi to 3000 psi. You can get that reading by stalling the splitter cylinder in the extended position. To adjust the detent on the splitter valve retract: remove the yellow cap and turn the adjustment bolt in to hold tighter. See Fig 10

The bearings should be greased with one shot of grease every 200 hours of use.

The engine must be maintained according to the instructions of the engine manual. The saw chain (.404) must be sharpened or replaced whenever it is dull. If it dulls on one side it may pull the bar to the side and cause binding. This machine's 25 inch bar requires an 89 tooth drive link for its chain. The hydraulic fluid is standard 46 weight hydraulic fluid. Keep the soft start pivot greased daily.

See Fig 11.

Change the hydraulic filter every 250 hours of use. See Fig 12.

Check the air filter every 20 hours. Clean them if dirty. Change the engine oil every 50 running hours (CAT Diesel every 250 hours).

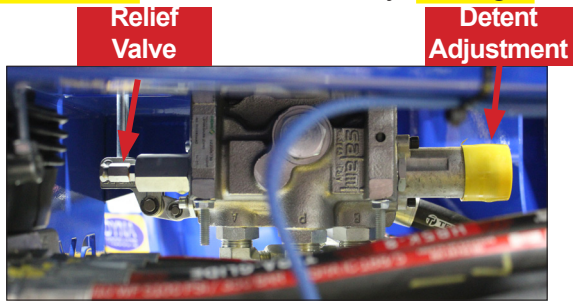

Fig. 10

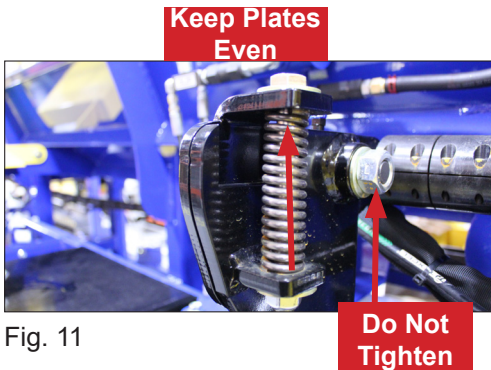

Fig. 11

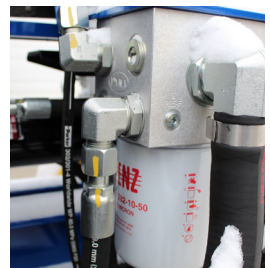

Fig. 12

SC-15 • TROUBLE SHOOTING

PROBLEM	SOLUTION
SAW MOTOR STALLS	The pressure on the saw feed cylinder may be too high. It should be approximately 75 psi. See Fig. 9. The soft start spring may be set too hard or the saw chain may be dull. Check splitter pressure to make sure it is in correct parameters.
THE SPLITTER STALLS	The pressure may be too low. This should be between 2500-3000 PSI. See Fig. 10.
SAW MOTOR STARTS HESITANTLY OR SLOWLY	The relief valve on the clamp may be set too low. It should be set at 600 psi. See Fig. 9. The aluminum cap on top of the selector valve may need to be cleaned.
SAW LACKS POWER	The relief valve may be set too low on the splitter valve. The aluminum cap on top of the selector valve may need to be cleaned. See Fig.10.
THE SAW BAR DOES NOT CUT ALL THE WAY THROUGH THE LOG	Increase sawfeed pressure to 95 psi Replace bar and chain. A worn bar will cause a good chain to bind .
SPLITTER DETENT NOT HOLDING TILL FULLY RETRACTED	With hydraulic oil warmed to operating temperature. Adjust detent adjustment bolt in until it holds..
THE SAW BAR HITS GUARD WHEN IT RETURNS	The saw bar pivot needs adjustment forward. Check that the softstart plates are even on the top when the sawbar is in the up position. See Fig.11 Adjust the sawfeed cylinder clevis up.
ENGINE STARTS HARD	Use fresh clean fuel. Do not use ethanol type fuels. Check and replace air and fuel filters Check spark plugs(on gas models) Check glow plugs(on diesel models).

SC-16 • SET UP

SETTING UP YOUR FIREWOOD PROCESSOR

 Read and understand this entire section for proper and safe set up.

To set up the firewood processor conveyor, follow these steps:

1. Lower with the electric winch until the wheels touch the ground.

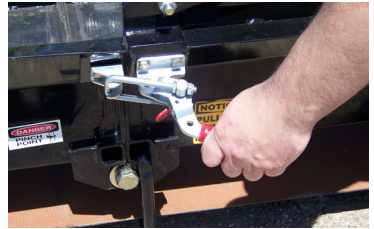

Fig. 1

2. Snap the locks securely into place, see Fig 1.

3. Raise the conveyor to a convenient height, see Fig 2.



Fig. 2

 NEVER stand underneath the conveyor.

 ALWAYS USE SAFETY CHAIN ON CONVEYOR!

SC-16 • SET UP CONT'D

THE CAT ENGINE:

RPM is set at the factory. Do not adjust this without consulting factory. The engine is preheated by turning the key one click. When the light goes out you may crank the engine. The throttle button must be pushed before pulling. Release the button when fully extended this locks the engine speed.

The oiler must be turned on at all times to supply oil to the saw bar. You should see a small amount of oil dripping off the chain sprocket. The bar should be getting enough oil to prevent discoloring from overheating. If you get excessive oil, you may experience a spray or mist hitting the operator. This indicates too much oil. The system will automatically apply oil every time the saw bar comes down. You will need to watch the oil level.

THE HYDRAULIC SYSTEM uses **46 weight hydraulic fluid**. Keep the oil level checked daily. It should always be in between the high and low marks on the level gauge. The temperature gauge is also on the level. The **tank holds 50 gallons of oil**. Check the level before you run the machine.

The log decks needs to be lowered before the logs can be placed on top. Be careful to keep hands away from the hinge points. These are serious pinch points and can cause serious injury, see Fig 3. The legs must be dropped to the ground or set on blocks and pinned into place



SC-16 • SET UP CONT'D & OPERATION

The logs can now be loaded onto the log deck. Never load logs from the engine side of the machine. It works best to keep the row of logs single without piling them on top of each other. ALWAYS keep out from under the logs on the deck. They could drop and cause serious injury.

OPERATING THE MACHINE

The logs can now be advanced toward the in-feed trough and deposited one at a time.

The joystick controls have appropriate instructions for the travel direction of the chains. See Fig 4. Be sure to use only one function per joystick simultaneously.



Fig. 4

The log is then brought into position to the orange marker. See Fig 5.

Next, pull the lever for the clamp, when it is clamped, the log saw will automatically start and travel through the log. The log will drop into the splitter hopper and the lever must be pushed the opposite direction to raise the saw. The clamp will open when the saw reaches the upper position.



Fig. 5

The log is split using the middle splitter lever. The 4-way wedge may be raised to the log's center to maximize the split. Be sure and keep the log centered across the wedge especially with the 4-way wedge. **NEVER** split with excess log mass on horizontal wedge wing only. This causes excess fatigue on the wing and can bend or break it. The warranty on the wedge is voided if this happens.

While the splitter is returning, you may advance the log into position again. You must never attempt to saw a log while the

SC-16 • OPERATION

splitter ram is in motion. These two functions should be operated independently for best results. The splitter valve will automatically snap into neutral when the cylinder bottoms out.

After the wood exits the splitter, it will push itself out onto the conveyor (if supplied). The conveyor may be turned on by the control knob. See Fig. 6 the speed may also be varied by this valve. The conveyor can be adjusted for height with the electric winch. Always be sure to stay away and out from under the conveyor at all times.

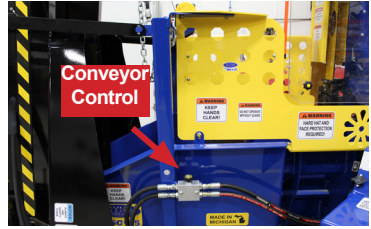

Fig. 6

HYDRAULIC ADJUSTMENTS

The relief valve pressures always adjust higher by turning clockwise or tight. The relief valves have a cap that needs to be turned off and a jam nut that needs to be loosened before adjusting.

The Saw Motor Pressure should read 2800 psi. To test this pressure, check while stalling sawing through a large piece. This is adjusted by the relief valve on the relief valve block. See Fig 7.

The Clamp Pressure should be approximately 600 psi. This can be read by completely lowering the clamp at a stall. If this is too low or too high, the saw motor will start softly or hesitantly. The relief valve for this is located on the top of the control block

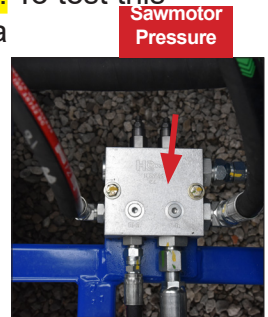

Fig. 7

The Splitter Pressure should read approximately 3000 psi with a 49 HP CAT or 56 HP KDI engine.

You can get that reading by stalling the splitter cylinder in the extended position.

To adjust the detent remove the

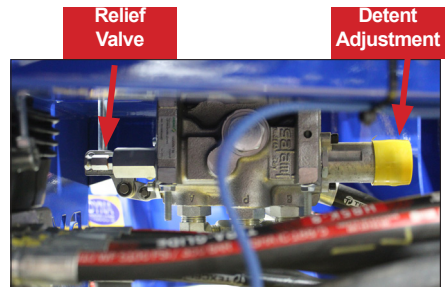

Fig. 8

SC-16 • OPERATION CONT'D

yellow cap and turn adjustment bolt in to increase pressure. See Fig.8

Your machine is equipped with a dedicated oiler system, flow control for the dedicated oiler is located on the oiler pump see Fig. 9 adjusting knob counterclockwise will increase flow and clockwise will decrease oil flow.

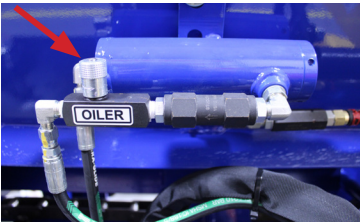

Fig. 9

MAINTENANCE

The Saw Feed Pressure should be set at approximately 110 psi.

If it is adjusted too high, the saw motor will stick and stall. If it is too low it may feed too slowly or it may pulse. Try to adjust it high as possible with out stalling the saw. The relief valve is located on the side of the control block, the hand knob. See Fig 10

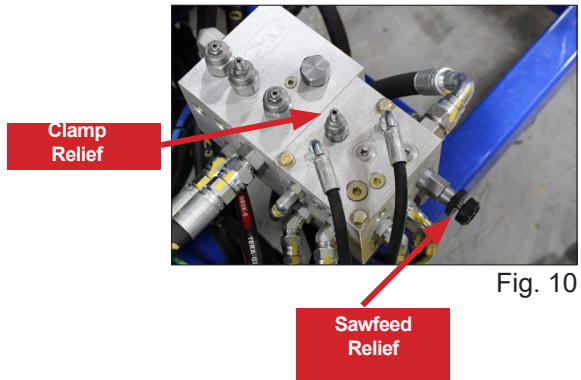

Fig. 10

SC-16 • MAINTENANCE

The bearings should be greased with one shot of grease every 200 hours of use. The engine must be maintained according to the instructions of the engine manual. The 404 chain needs to be sharpened or replaced whenever it is dull. If it dulls on one side it may pull the bar to the side and cause binding. Your SC-16 has a 25" harvester bar and runs an 89 tooth drive link for its chain.

The hydraulic fluid is a standard 46 weight hydraulic fluid. Keep the Soft Start pivot greased daily. See Fig 11. Change the oil and filter every 250 hours of use. See Fig 12.



Fig. 12

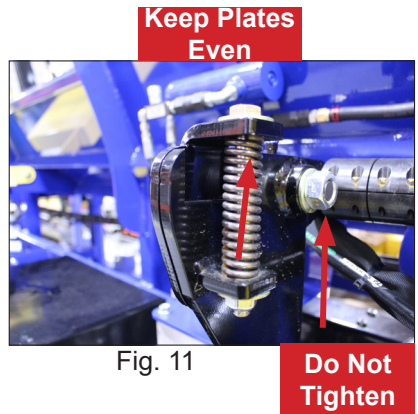
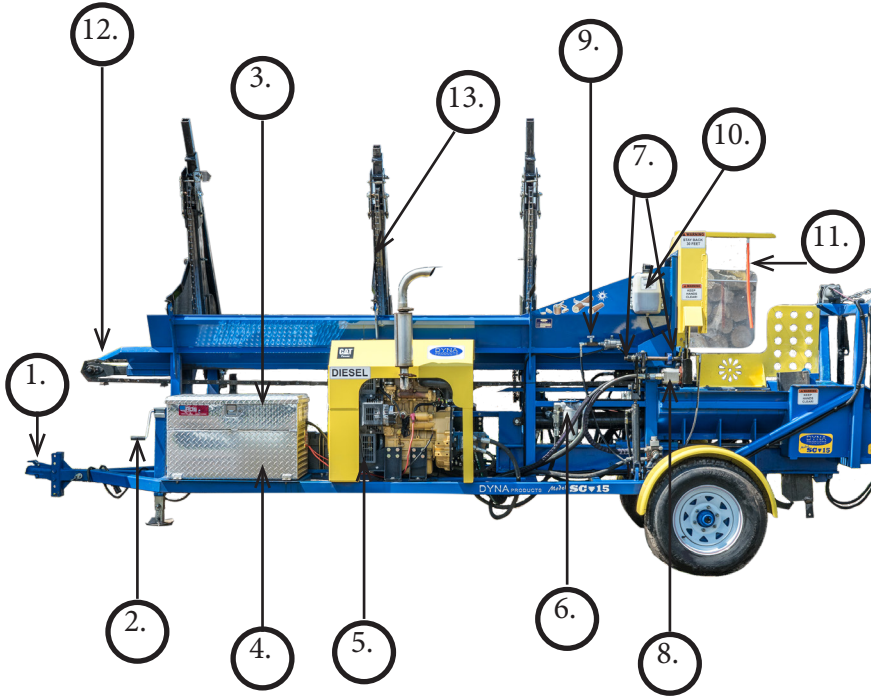

Fig. 11

SC-16 • TROUBLE SHOOTING

PROBLEM	SOLUTION
SAW MOTOR STALLS	The pressure on the saw feed cylinder may be too high. It should be approximately 110 psi. See Fig. 11. The soft start spring may be set too hard. The saw chain may be dull.
THE SPLITTER STALLS	The pressure may be too low. This should be between 2500-3000 psi. See Fig. 9.
SAW MOTOR STARTS HESITANTLY OR SLOWLY	The relief valve on the clamp may be set too low. It should be set at 600 PSI. See Fig. 11 The engine may not be properly accelerated. The aluminum cap on the selector valve needs cleaning.
SAW LACKS POWER	The relief valve may be set too low on the pump.
THE SAW BAR DOES NOT CUT ALL THE WAY THROUGH THE LOG	The saw chain is dull. Increase the saw-feed pressure to 100 psi Replace bar and chain. A worn bar will cause a good chain to bind.
SPLITTER VALVE DOESN'T HOLD IN THE RETRACT DETENT	Warm the oil to operating temperature. Adjust detent until it holds. See Fig 9
THE SAW BAR HITS GUARD WHEN IT RETURNS	The saw bar pivot needs adjustment forward. Check that the softstart plates are even on the top when the sawbar is in the up position. See Fig.12 Adjust the sawfeed cylinder clevis up.
ENGINE STARTS HARD	Check engine glow plugs. Use the block heater in cold weather. Replace fuel filters. Use fresh, clean, nonbio-diesel fuel

SC-14/SC-15/SC-16• Parts Reference



- 1. Hitch
- 2. Front Jack
- 3. Tool box
- 4. Fuel Tank
- 5. Engine
- 6. Hydraulic Filter
- 7. Saw Motor Assembly
- 8. Saw Motor
- 9. Oil Adjustment Valve
- 10. Bar & Chain Oil Reservoir
- 11. Measurement Bar
- 12. Trough Chain
- 13. Deck Chain #2060 Chain

SC-14/SC-15/SC-16• Parts Reference

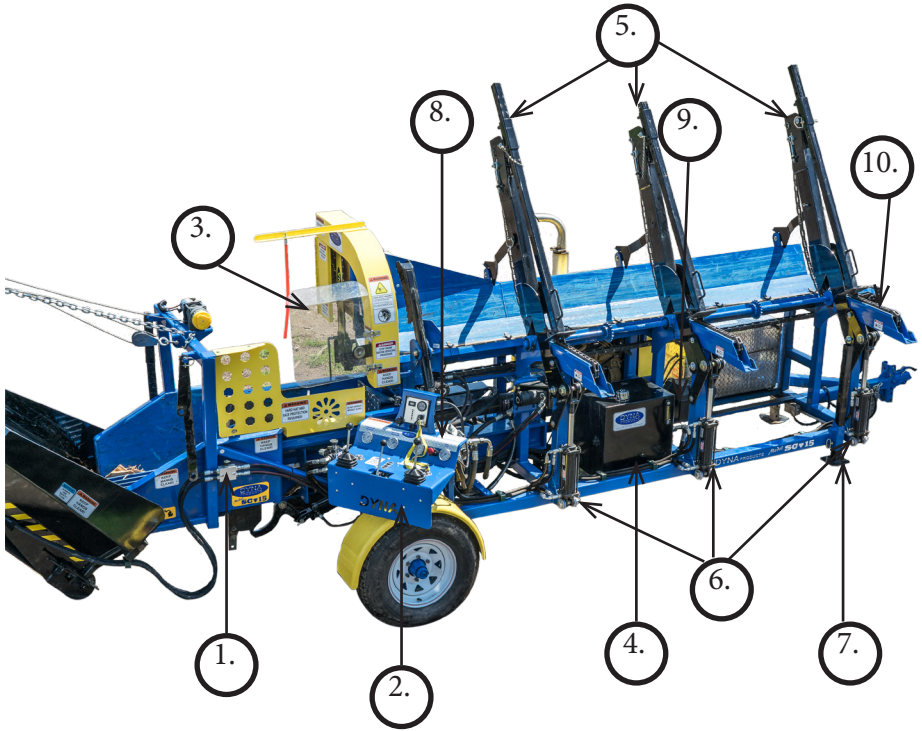

1. Conveyor Control
2. Control Station
3. Safety Shield
4. Hydraulic Tank
5. Live Deck Legs
6. Hydraulic Live Deck Cylinders
7. Stabilizer Leg
8. Control Block
9. Battery
10. Deck Chain #2060

SC-14/SC-15/ SC-16• Parts Reference



1. Oregon Bar
2. Clamp
3. Wedge
4. Splitter
5. Wedge Cylinder
6. Oiler Pump
7. Soft Start
8. Selector Valve
9. Saw Motor

SC-14/SC-15/ SC-16• Parts Reference

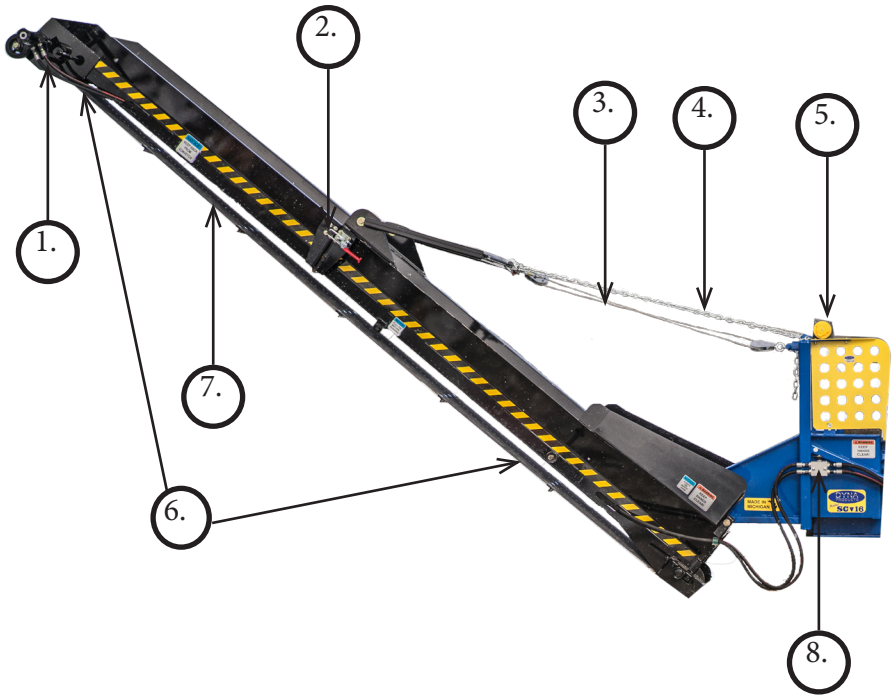

1. Conveyor Motor
2. Safety Latch
3. Winch Cable
4. Safety Chain
5. Winch
6. Transport Safety Bars
7. Conveyor Belt
8. Conveyor Speed Control

SC-14/SC-15/ SC-16• Parts Reference

DETENT ADJUSTMENT ON SPLITTER VALVE

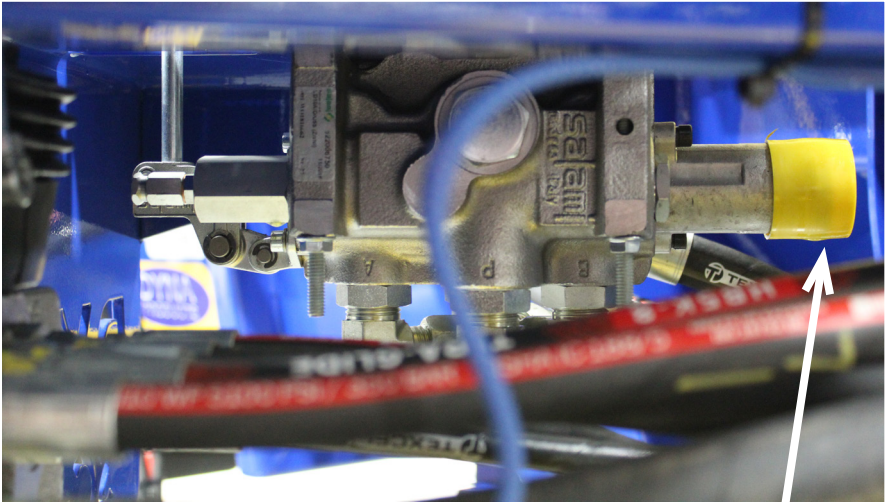

- (1) REMOVE YELLOW CAP
- (2) TURN CLOCKWISE APPROX $\frac{1}{4}$ TURN TO INCREASE DETENT,

Instruction For Sawbar Maintenance

Step 1. First grind the rails on the one side of the sawbar by starting at the tip of the bar (make sure the grinding wheel is in between two teeth of the sprocket) and slowly rotate the saw bar then continue down the sawbar. (Make sure your grinding table is exactly 90 degrees from the grinding wheel.) Check the bar rails for any undercuts in the rails. Grind the bar until all chips or undercuts have disappeared. Flip the bar and do the other side.

Step 2. Make sure chain oil ports in the sawbar are open. A thin wire (i.e. welding wire) and an air nozzle work well if they are plugged.

Step 3. Take a light sanding disc (an angle die grinder works well, but a palm sander or something similar would also work) and sand the edges of the bar to remove all the burs.

Step 4. Take a bar cleaner tool (a Leatherman® multi-tool also works well for this) and clean all the debris out of the bar rails. Now take a spray cleaner (Sprayon® CR757 citrus degreaser or Transtar Autobody Technology®'s Acry Solvent work well) and spray it into the the saw bar rails and sprocket. Now take an air nozzle and blow into the rails and sprocket to remove any metal particles. (If left in the bar, these metal particles will act like sandpaper which would cause damage to your bar, sprocket and chain) The sprocket should turn if you blow onto it with your air nozzle, if it doesn't you should spray more cleaner on the sprocket and work it in a little. The sprocket should now turn freely if you blow onto it.

Step 5. Now pour some oil (bar & chain oil or air tool oil both work well) it to the sprocket and along the rails on both sides of the saw bar.

CHAIN MAINTENANCE/SHARPENING

- Always set the clamp assembly at 35° for the left-hand side and right-hand side
- Always set the grinding head assembly at 60°
- Always use the 3/16 grinding wheel. It will come along with your grinder(Optional diamond grinding wheels are available. Though more expensive it is faster and decreases risk of burning the tooth.)
- Dress your vitrified grinding wheel often to maintain correct shape. (use the dressing brick that will come with your grinder, also use the gauge to check if it is the right shape)(this procedure is not needed with a diamond grinding wheel)
- Always be sure you do not burn the saw-chain tooth. This will weaken the tooth and it will lose its sharpness very quickly. To avoid burning the tooth, use light, intermittent strokes.

Continued Chain Maintenance/Sharpening

- Sharpen damaged teeth back to undamaged part. Sharpen rest of teeth to the same length.
- Always sharpen the side with the shortest teeth first. To determine this, hold the saw-chain with your left hand, now take hold of the bottom of the chain with your right hand, next bring your right hand up to your left hand, compare the left-hand tooth to the right-hand tooth. Now find the shortest or most damaged tooth on the shortest side. Sharpen this tooth, then sharpen the rest at the same length.
- Always keep cutters at the same length. Due to inaccuracy of your grinder you will need to check your chain after you sharpen the first tooth of the second side. Check to see if it is the same length as the first side by using the procedure noted in above section.
- Setting the depth gauge. Sharpen the tooth before filing the depth gauge. Use an .050 Oregon® depth gauge tool for .404 18HX saw-chain. Check your chain every 3-4 sharpening. Place the tool on top of the saw-chain so that one depth gauge protrudes through the slot in the tool. If the depth gauge extends above the slot, file it down level with the tool with a flat hand file or the intended grinding wheel (included with the grinder). File from the inside of the round ground saw-chain teeth to the outside. See in Fig 1

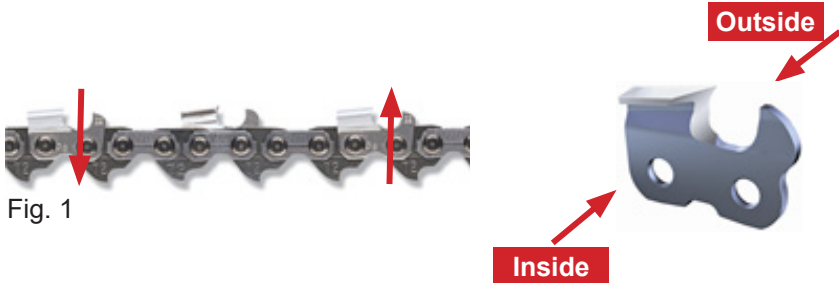

For more information, contact your nearest Dealer or DYNA Products at:

DYNA Products

8440 State Rd
Millington MI 48746 USA
888-820-3962 Toll Free
231-734-4433 Local Phone
231-734-3681 Fax
info@dyna-products.com



Model # _____

Serial # _____

Date Purchased _____

Purchased By _____